



Standard Colors:  
Red or White

## Sound Attenuated Diesel Generator

Global Prime Power generators are specifically designed to provide prime power or temporary power anywhere and anytime utility power is not available.

These compact, mobile, sound attenuated generators provide single- and three-phase power simultaneously for construction, commercial, industrial, emergency, and special event applications.

GP75

### FEATURES

- Rugged design for portable power applications.
- Heavy duty, direct injection Perkins diesel engine provides maximum reliability.
- Brushless alternator with Permanent Magnet Generator (PMG) for superior motor starting.
- Premium Automatic Voltage Regulator (AVR) with three-phase rms sensing for improved regulation and performance.
- Automatic start/stop contacts allow the unit to start upon a signal from a transfer switch during a power failure.
- Voltage selector switch allows an easy change to a wide variety of voltages. Fine tune to exact requirements by adjusting the voltage rheostat on the front control panel.
- Sound attenuated, weather resistant, electrostatic powder paint, lockable enclosure with center lifting point for safe, unattended, quiet operation.
- Simultaneous three-phase and single-phase output.
- Cam-Lock connectors to provide a quick connection alternative.
- Reduced operating cost with 500 hour service intervals and fuel-efficient diesel engines.
- Large internal fuel cell for extended runtimes between refueling.
- Environmentally friendly skid with 110% fluid containment and forklift pockets.
- Easy-to-read Digital controller with safety shutdowns for safe, accurate generator and engine monitoring.
- Trailer with flush mount DOT lighting, safety chains, adjustable height couple, and electric brakes.
- EPA emission compliance to 40 CFR 1039.625.
- Engine warranty with 2 year or 2000 hours, plus 12 months on major components.

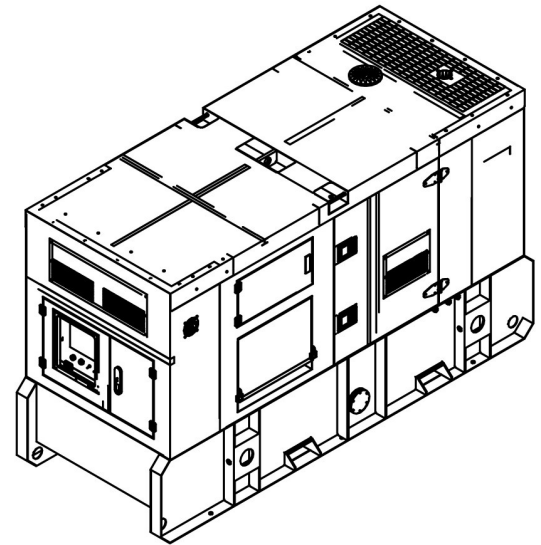
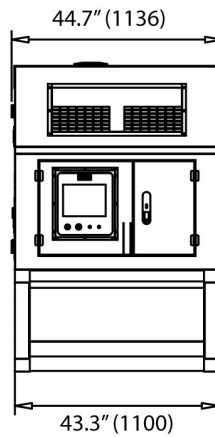
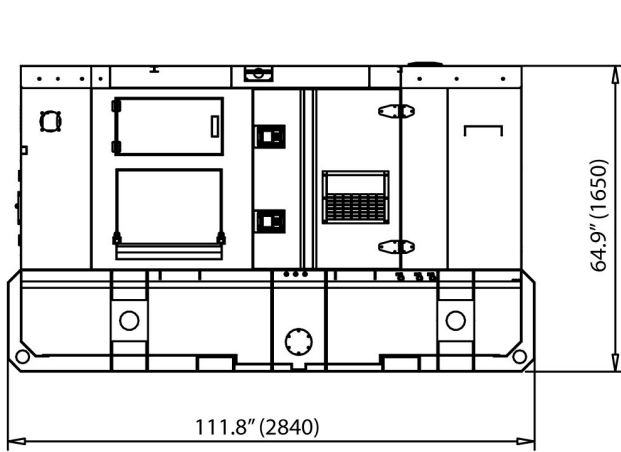

## SPECIFICATIONS

### GENERATOR DATA

Model	GP75-SA376
Rated Standby Power @ .8pf	65kW (81kVA)
Rated Prime Power @.8pf	59kW (73kVA)
3Ø Voltage Selections	Switchable 208/120, 220/127, 240/139 480/277, 460/266, 440/254
1Ø Voltage Selections	120/240
Amperage Capacity @ 120V 1Ø	163 Amps X 2 (Zigzag)
Amperage Capacity @ 240V 1Ø	163 Amps (Zigzag)
Amperage Capacity @ 208V 3Ø	203 Amps
Amperage Capacity @ 240V 3Ø	177 Amps
Amperage Capacity @ 480V 3Ø	88 Amps
Connection Terminals and Receptacles	1-Single row mechanical lug, hex head 1-Single row color coded Cam Locks 2- 20A, 120V GFCI 3- 50A, 250V, CS6369
Sound Level Full Load @ 23'	69 db(A)
Fuel Cell Capacity	124 gallons (470 liters)
Fuel Consumption	gph (lph)
100% Load	4.9 (18.8)
75% Load	3.9 (14.9)
50% Load	2.8 (10.7)
25% Load	1.6 (6.2)
Controller	Deepsea 7310
Safety Protection	Water Temp, Oil Pressure Emergency Stop Button kW/kVA/Amp Parameter Monitoring Battery Disconnect Lockable Voltage Selection Generator Output Protection

### ENGINE

Engine Make	Perkins
Engine Model	1104D-E44TAG1
Emissions Compliance	EPA Tier III
Design	4 Cylinder, 4-cycle, water cooled, direct injection, turbocharged
Displacement	4.41 liter
Rated Speed	1800 rpm
Gross Engine Power Output	129HP (96kw)
Oil Capacity	2.1 gallons (8.0 liters)
Battery	12V 100Ah x 1

### ALTERNATOR

Model	Stamford UCI224F
Excitation	Brushless with PMG
Automatic Voltage Regulator	Stamford MX321
Frequency	60 Hertz
Voltage Regulation	±0.5%
Frequency Regulation	±.25%
Insulation	Class H
T.I.F.	<50

### SKID DIMENSIONS

	Inch (mm)
Length	111.8 (2840)
Width	43.3 (1100)
Height	64.9 (1650)
Weight (dry)	4056 lbs (1840 kg)

### TRAILER OPTION

Standard Dual Axle  
Electric/Surge Brakes  
DOT Approved Recessed Lighting

GP75



Rain2Day, Inc.  
4740 Industry Park Court  
Las Vegas NV. 89115  
P- 702 395-8849  
F- 702 320-9959  
www.rain2day.com